

INSTRUCTIONS FOR THE FOLLOWING FIXTURES:

ORDER#	MODEL#
R83001	RENO-EM-H15
R83002	RENO-EM-H25

Features:

- Standard CSA C22.2 NO.141、UL924、IP65
- Output emergency power 15W or 25W
- Universal input (100-347VAC)
- Built-in Lithium Battery
- Battery protections: over charge protection, over discharge protection, short circuit protection
- The batteries meet 500 cycles of standard charge and discharge
- Silicone potted
- Waterproof Rate: IP65

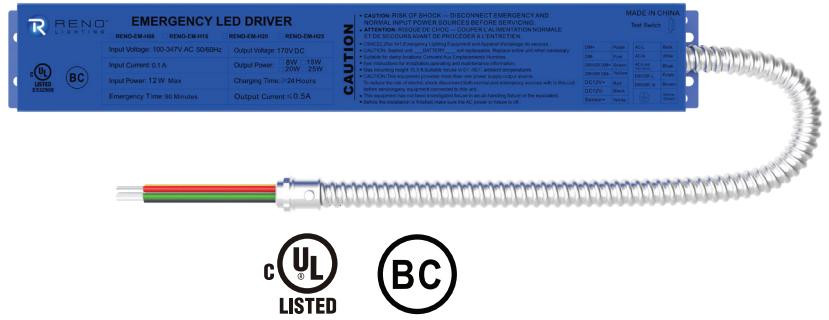

Note before Install: If your installation is using an integrated sensor with the luminaire, ensure the sensor **Standby Period** is set to **"infinite"** so that the light does not shut off during emergency mode.

Wiring Diagram

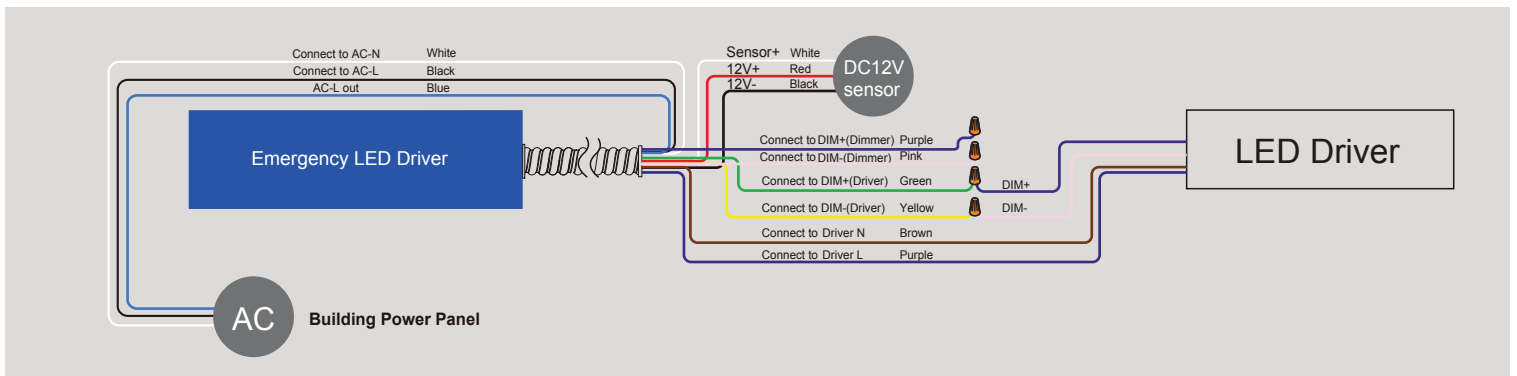

NOTE: IF NOT USING A DC 12V SENSOR, DO NOT CONNECT THE RED 12V+ WIRE

Dimensions: Case-12.99"×1.97"×0.93"(mounting center-12.48")

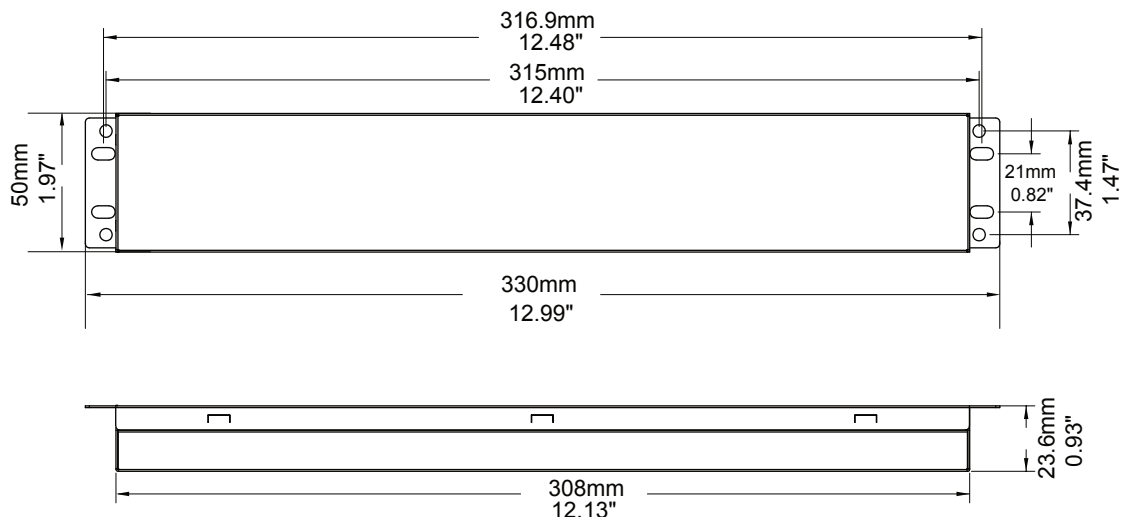

SAFETY INSTRUCTIONS

- **IMPORTANT:** Customers are advised to charge emergency LED driver 24 hours every 6 months during storage.
- Risk of fire or electric shock. Luminaries wiring and electrical parts may be damaged when drilling for installation of LED emergency backup. Check for enclosed wiring and components.
- Risk of fire or electric shock. This LED emergency backup installation requires knowledge of luminaries electrical systems. If not qualified, do not attempt installation. Contact a qualified electrician.
- Before installing, make certain the AC power to the fixture is off.
- The electrical rating of this product is 100–347V. Installer must confirm that there is 100–347Vac the fixture before installation.
- To prevent electrical shock, only mate unit connector after installation is complete and before the AC power to the fixture is back on.
- This LED Emergency Backup unit requires an un-switched AC power source of 100–347V, 50/60 Hz.
- Do not let power supply cords touch hot surfaces.
- Do not mount near gas or electric heaters.

INSTALLATION INSTRUCTIONS

1. Ensure the power is turned off and locked out for the circuit you are working on. Always consult a qualified electrician.
2. Mount the RENO- EM-H15/H25 to the back plate of the fixture (please consult the manufacturer's installation sheet for the correct placement of a emergency LED driver).
3. Open the 1/2" knockout on the fixture.
4. Insert Emergency Driver BX into the knockout and tighten the locknut.
5. Connect your grounds together (Green wire).
6. Connect the White(Neutral) of the RENO- EM-H15/H25 to the branch circuit of the building neutral.
7. Connect the Black(Hot) of the RENO- EM-H15/H25 to the building hot wire (This is intended to be constantly powered for the charging of the battery pack).
8. Connect the Blue (Hot) to the Switched line to be able to turn off the fixture without triggering the emergency mode. (If your fixtures are always on, connect this to the black (Hot)). Please note that if the fixture is shut off, the emergency battery will be active.
9. Connect the Brown wire of the RENO- EM-H15/H25 to the white (neutral) of internal fixture driver.
10. Connect the Purple wire of the RENO- EM-H15/H25 to the Black (Hot) of the internal fixture driver.

INSTALLATION INSTRUCTIONS (CONT'D)

VERY IMPORTANT STEPS BELOW

Not following these instructions will result in the fixture strobing in overcurrent protection mode. These drivers will only work with a 0-10V enabled fixture. In a power loss situation, the fixture will dim to 10% to achieve the runtime for path of egress.

11. Locate the separate cab-tire harness and cut off the quick connects that are provided.
12. Connect the Yellow (Driver Dim-) to the Pink (Dim-) of the fixture driver- This is located between the sensor socket and driver.
13. Connect the Green (Driver Dim+) to the Purple (Dim+) of the fixture driver located between the sensor socket and driver.

OPTIONAL

If a 12vdc sensor is being used, please connect the EM Driver's Red 12V+ to the Yellow 12V+ of the sensor socket and disconnect the 12V+ output from the internal fixture driver.

If a dimmer is being used, please connect the EM driver's Pink(Dim-) to the Pink(Dim-) of dimmer; connect the EM driver's Purple(Dim+) to the Purple(Dim+) of dimmer

There is a knockout on the bottom center pan of the fixture to accommodate the test button. Install the test button and plug into the prewired harness.

Reinstall bottom center pan and turn the circuit back on.

The test button should illuminate and flash to indicate the battery is charging.

Pressing the test button will dim the fixture for 5 seconds to indicate correct wiring.